



STOCK CODE 301317

PISTON AIR COMPRESSOR OEM SELECTION MANUAL

XINLEI COMPRESSOR CO.,LTD.

Add: No.8, Chaoping Street, East Industry Center, Wenling, Taizhou City, Zhejiang Province, China

Zip Code: 317511

WhatsApp: +86 19579673005

Email: xinleiglobal@xinlei.com

Web: <https://www.xinleiglobal.com/>

All the trademarks mentioned in this catalog belong to Xinlei compressor co., ltd and its affiliated companies or related owners.

The information description in this catalog is not suitable for all situations due to the difference of time and recipient. The specific information shall be implemented according to the contract.

The models and technical parameters provided in this catalog are subject to the actual products and may be changed without notice. Thanks for understanding.

Please contact the sales person for more product information and service materials, Xinlei reserves the



WhatsApp

Facebook

LinkedIn

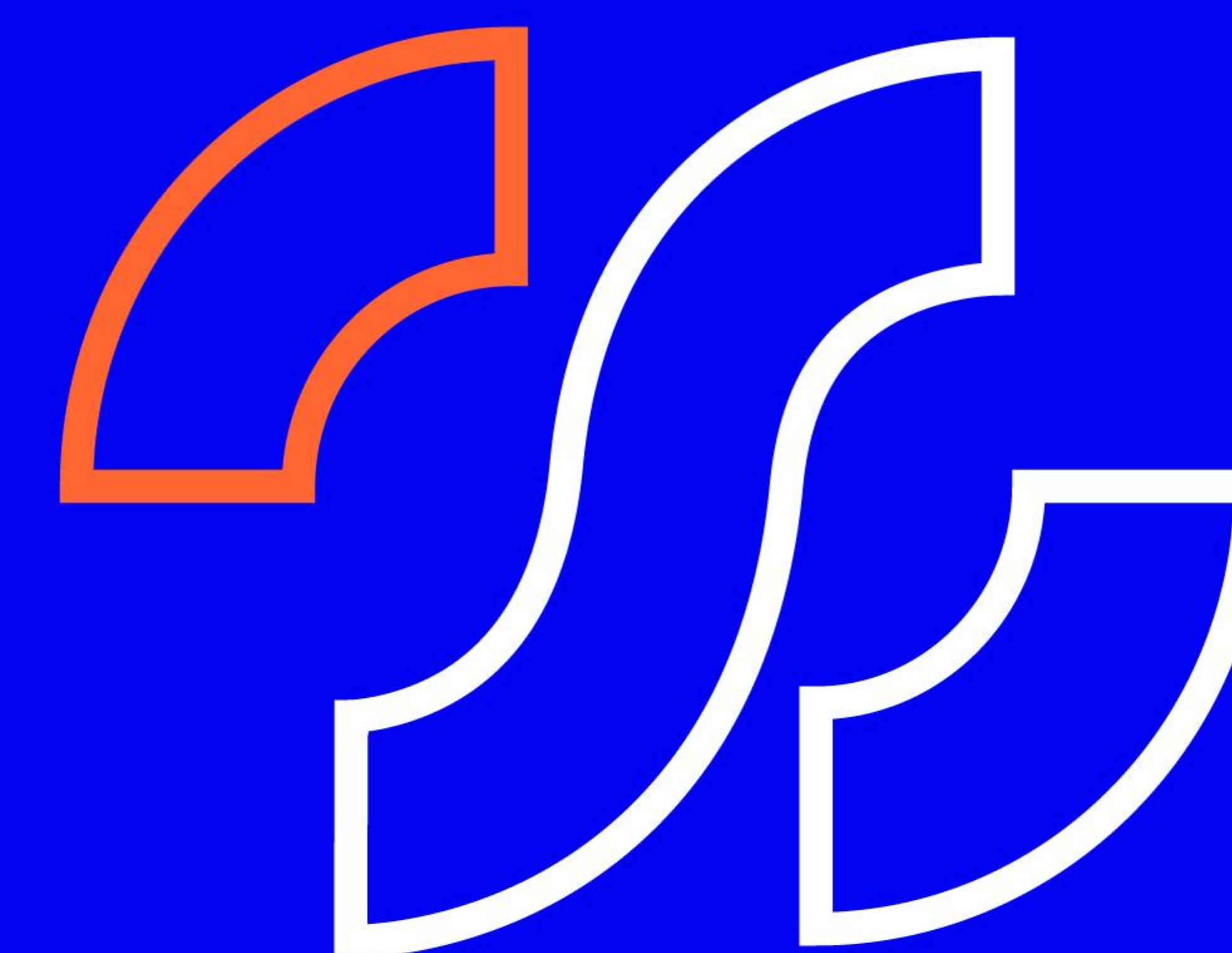

XINLEI COMPRESSOR CO.,LTD.

Focus on the customer's challenges and pressures. Provide competitive air energy system solutions and services. Continue to create maximum value for customers.

Founded in Zhejiang, China in 2006. Xinlei is a high-tech enterprise with independent research and development intellectual property rights covering the whole fluid field such as piston, screw and centrifugal. We focus on aerodynamic full-scenario digital and intelligent solution, strive to be a world-class enterprise with world-class standards, create and share digital and intelligent fluid ecology with global customer partners.

AIR FOR ALL



**XINLEI
COMPRESSOR
CO.,LTD.**

149,000+m²
floor area

800,000+
units yearly
production

100+
sales area

300+
patents

300+
product
specifications

260+
high quality
precision
equipment

COMPANY HONOURS

Draft 6 national standards & 4 industrial standards & 7 Team standards

High-tech enterprise

National Development and Reform Commission National Key energy-saving and low-carbon technology Promotion Catalogue yearly continuous

Zhejiang first batch of domestic and foreign trade integration "pacesetter" enterprises

Ministry of Industry and Information Technology "Energy Efficiency Star" equipment product catalog yearly continuous

National Torch Program Project Certificate

Vice president unit of China General Machinery Industry Association

The sixth council of China Equipment Management Association

The sixth council of China Equipment Management Association

Member of China Chamber of Commerce for Import and Export of Mechanical and Electrical Products

National Energy Efficiency Labeling Testing Laboratory

Petrochina and Sinopec Engineering Research Association-Air Compressor Technology Center

Zhejiang Provincial Enterprise Research Institute of Xinlei Fluid Machinery

Zhejiang export famous brand & "Made in Zhejiang" Standard

2020 Excellent supplier in cement industry

2021 China's industrial aquatic innovation equipment

Energy-saving products benefits project high energy efficient positive displacement air compressor promotion enterprise

PROCESSING STRENGTH

From raw material procurement, spare parts processing, complete machine assembly to performance testing, Xinlei always strict with quality control. The company has the world advanced MAZAK high-precision machining center, KAPP rotor grinder machining center, high-precision ZEISS CMM and robot configuration refinement processing center, to build Xinlei a refinement and advanced production&processing center, to ensure the core components of self-research and production, and the high efficiency collaborative accuracy.

260+

high quality precision equipment to guarantee the high quality of products

○ Fine machining center

○ KAPP rotor grinder machining center

ZEISS three-coordinate ○ testing center

○ MAZAK high precision machining center

PROCESSING STRENGTH

DIRECT DRIVEN PISTON AIR COMPRESSOR OIL-FREE



DIRECT DRIVEN PISTON AIR COMPRESSOR OIL-FREE

Basic



Semi-wrapped



Fully wrapped



OIL FREE AIR COMPRESSOR

Whirlpool Killer

- 10000h long life
- 100% oil-free & clean
- Automotive-grade components
- Wide pressure range
- Simple maintenance
- Ultra first-class energy efficiency
- Noise less than 72dB (A)

New Energy Buses

Automobile Brake Systems

Pneumatic Doors Of Emus

Maintenance Scenarios



ZBW60A-2V-3/10-100L



ZBW60A-2V-4/10



ZBW60A-2V-3/10



ZBW60A-V-1.5/10

OIL FREE AIR COMPRESSOR

- 100% oil-free & clean
- Built-in PTC thermal protection for motor
- Light weight, easy to carry
- Adopts series-excited motor, smaller and lighter than induction motor with a novel overall design

Spray gun

Nail gun

Home decoration

Tire inflation

Equipment cleaning



ZBW50U-1.1/10-BOX



ZBW50U-1.5/10-6L

ZBW50U-1.1/10-6L



ZBW50U-1.5/10-50LV

ZBW50U-1.1/10-50LV



ZBW50U-1.5/10-24LV

ZBW50U-1.1/10-24LV

OIL FREE AIR COMPRESSOR

- Integrated structure
- Oil-lubricated
- Simple operation and maintenance
- Wide pressure range
- Excellent piston sealing
- Motor with built-in PTC thermal protection

Spray gun Nail gun Home decoration Tire inflation Equipment cleaning

SILENT OIL-FREE

- 100% oil-free & clean
- Compact and portable
- Motor with built-in PTC thermal protection
- Low noise, quiet operation
- Industrial-grade piston and piston ring
- Multi-head combination by displacement

Spray gun Nail gun Home decoration Tire inflation Equipment cleaning



ZBW60-1.1/8-6L



ZBW60-1.1/8-24L ZBW60-1.5/8-24L



ZBW60BV-1.1/8-24F
ZBW60BV-1.8/8-24F



ZBW60BV-1.8/10-50L ZBW60BV-1.8/10-90L
ZBW60BV-1.8/10-100L

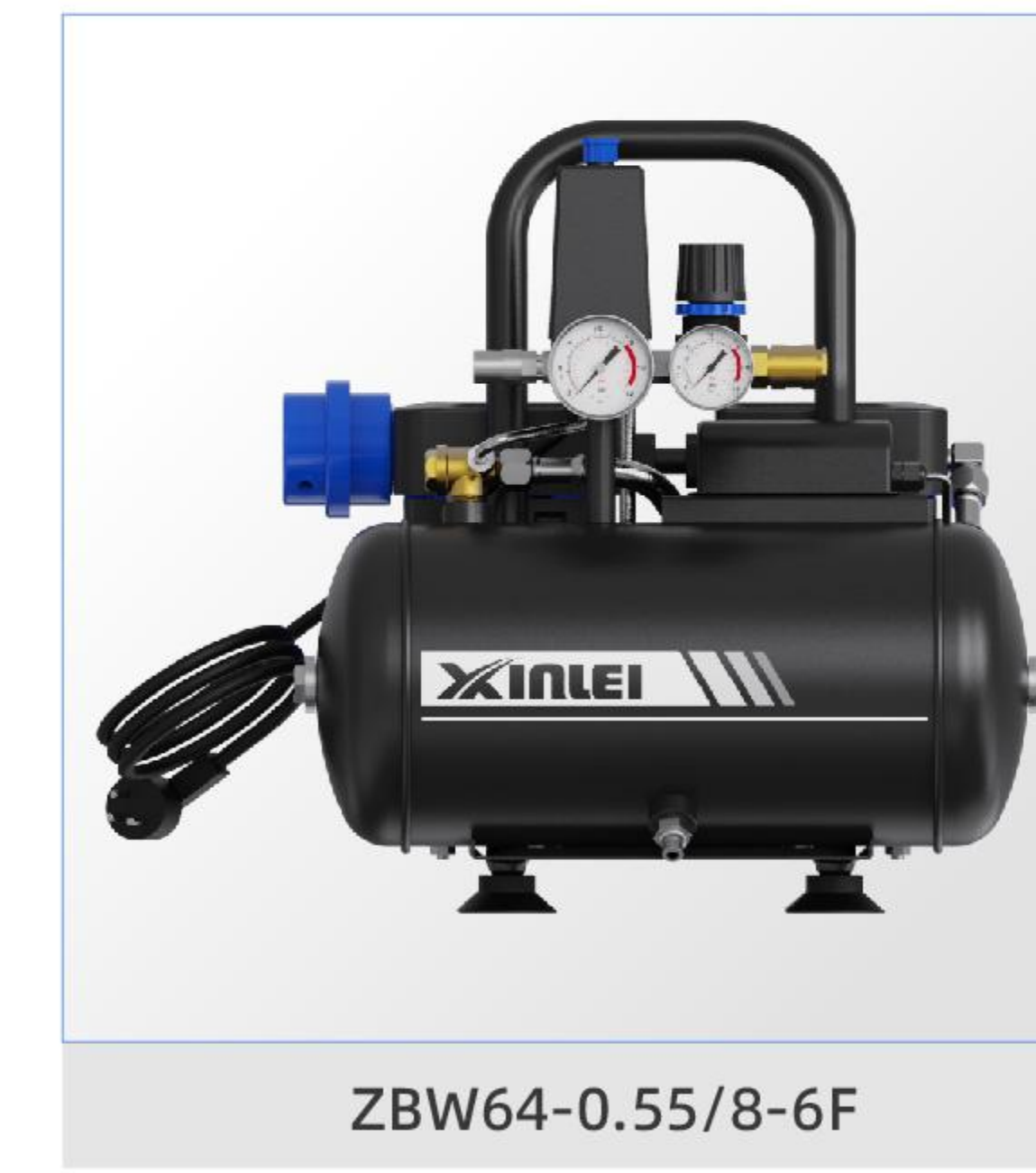

ZBW64-0.55/8-6F

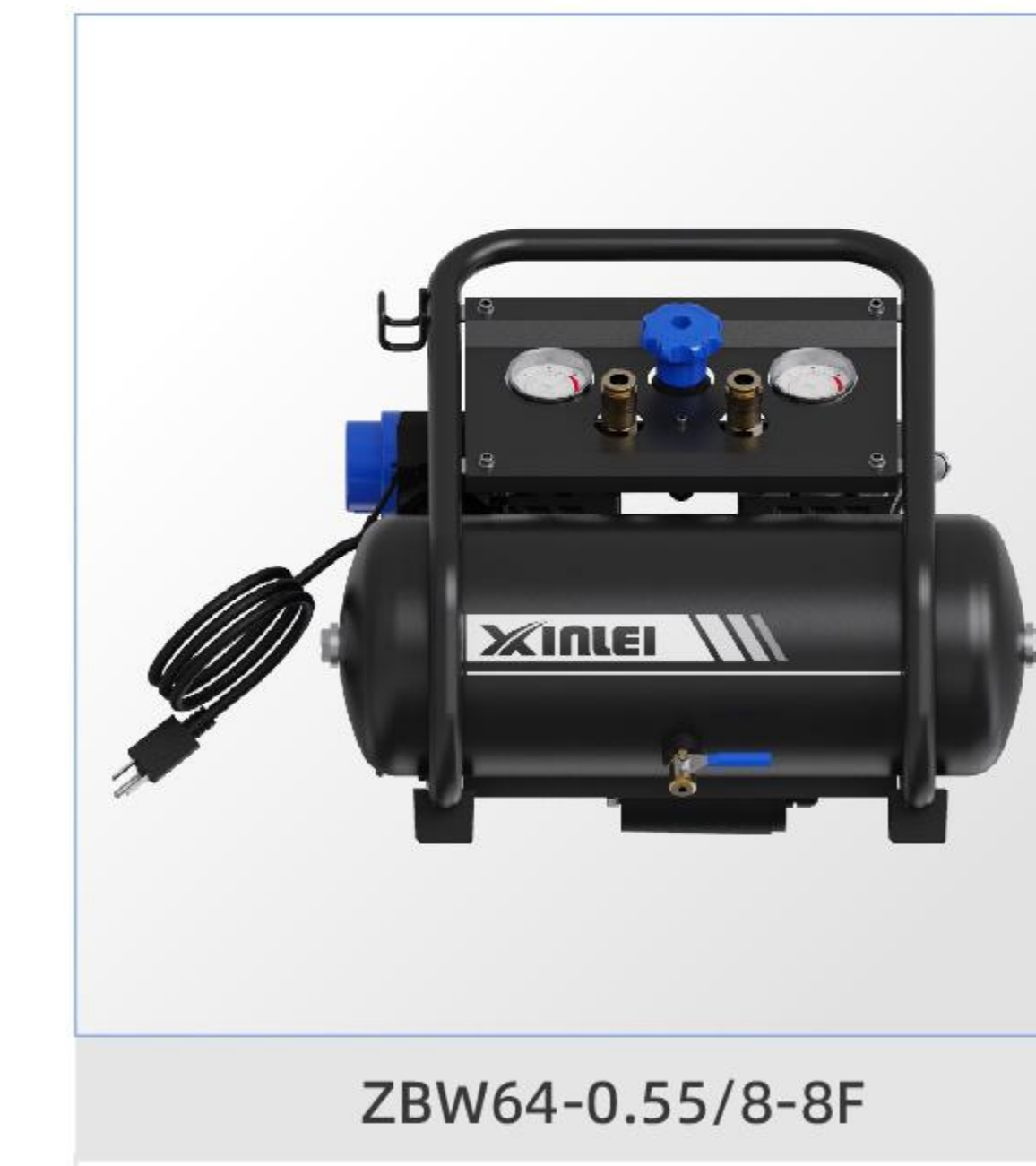

ZBW64-0.55/8-8F
ZBW64-0.75/8-8F



ZBW64-0.55/8-6H



ZBW64-0.55/8-8L
ZBW64-0.75/8-8L

SLIENT OIL-FREE

- 100% oil-free & clean
- Compact and portable
- Motor with built-in PTC thermal protection
- Low noise, quiet operation
- Industrial-grade piston and piston ring
- Multi-head combination by displacement

SLIENT OIL-FREE



Spray gun



Nail gun



Home decoration



Tire inflation



Equipment cleaning



ZBW64-0.75/8.6-4GTP



ZBW64-0.75/8-24L ZBW64-1.1/8-24L
ZBW64-1.5/10-24L ZBW64-0.55/8-24L



ZBW64-1.5/10-50L(750x2)



ZBW64-2.2/10-100L(750x3)



ZBW64-1.1/10-50L
ZBW64-1.5/10-50L



ZBW64-1.1/10-50L



ZBW64-1.1/10-50L(550x2)



ZBW64-3/10-200L

SLIENT OIL-FREE

- 100% oil-free & clean
- Compact and portable
- Motor with built-in PTC thermal protection
- Low noise, quiet operation
- Industrial-grade piston and piston ring
- Multi-head combination by displacement

SLIENT OIL-FREE



Spray gun



Nail gun



Home decoration



Tire inflation



Equipment cleaning



- ZBW64A-0.55/8-6F
- ZBW64A-0.75/8-6F
- ZBW64A-1.1/10-6F



- ZBW64A-0.5/8-8F
- ZBW64A-0.55/8-8F
- ZBW64A-0.75/8-8F
- ZBW64A/2p-1.1/10-8F
- ZBW64A/2p-1.5/10-8F



- ZBW64A-0.55/8-8L
- ZBW64A-0.75/8-8L
- ZBW64A-1.1/10-8L
- ZBW64A-1.5/10-8L



- ZBW64A-0.5/8-24L
- ZBW64A-0.75/8-24L
- ZBW64A-1.1/10-24L
- ZBW64A-1.5/10-24L

SILENT OIL-FREE

SILENT OIL-FREE

- 100% oil-free & clean
- Compact and portable
- Motor with built-in PTC thermal protection
- Low noise, quiet operation
- Industrial-grade piston and piston ring
- Multi-head combination by displacement

Spray gun Nail gun Home decoration Tire inflation Equipment cleaning



ZBW64A-0.55/8.6-10GV
ZBW64A-0.75/8.6-10GV



ZBW64A-1.1/10-50L



ZBW64A-1.5/10-50L(750x2)



ZBW64A-2.2-10/100L(750x3)



ZBW64A-3/10-200L



ZBW64A-2.2/10-100L

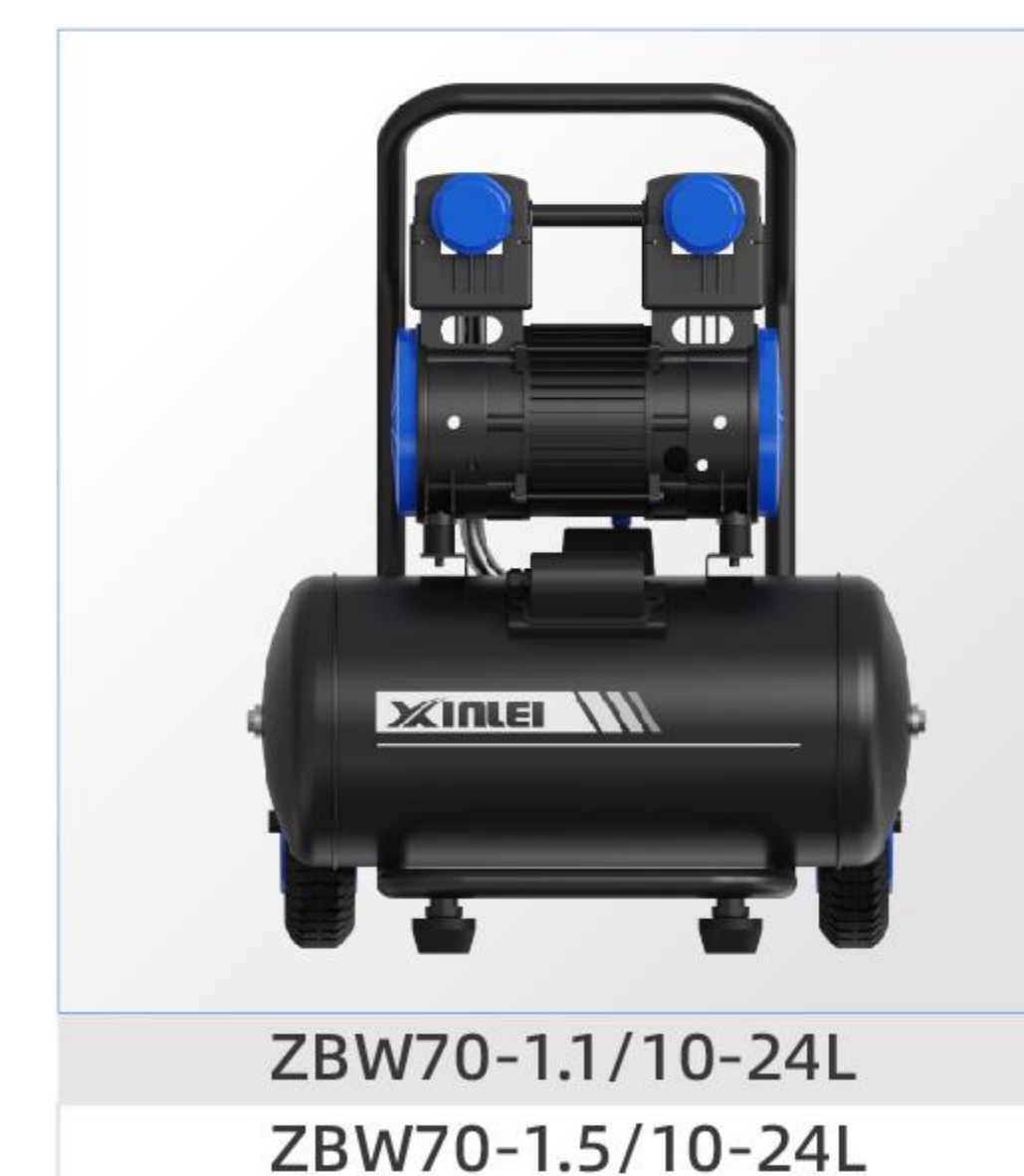

ZBW70-1.1/10-24L
ZBW70-1.5/10-24L



ZBW70-1.1/10-50L
ZBW70-1.5/10-50L

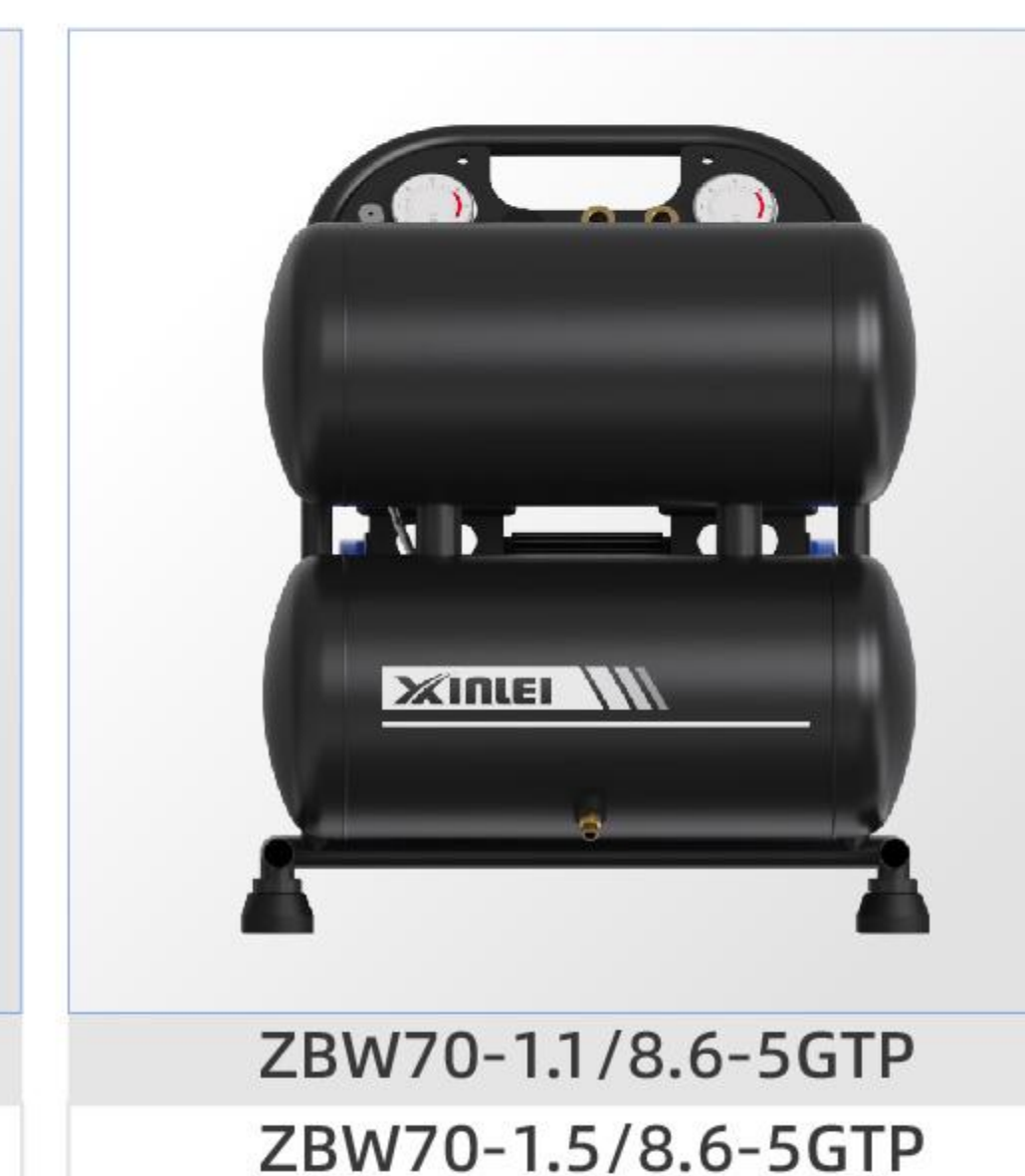

ZBW70-1.1/8.6-5GTP
ZBW70-1.5/8.6-5GTP



ZBW70-1.5/10-10GVP

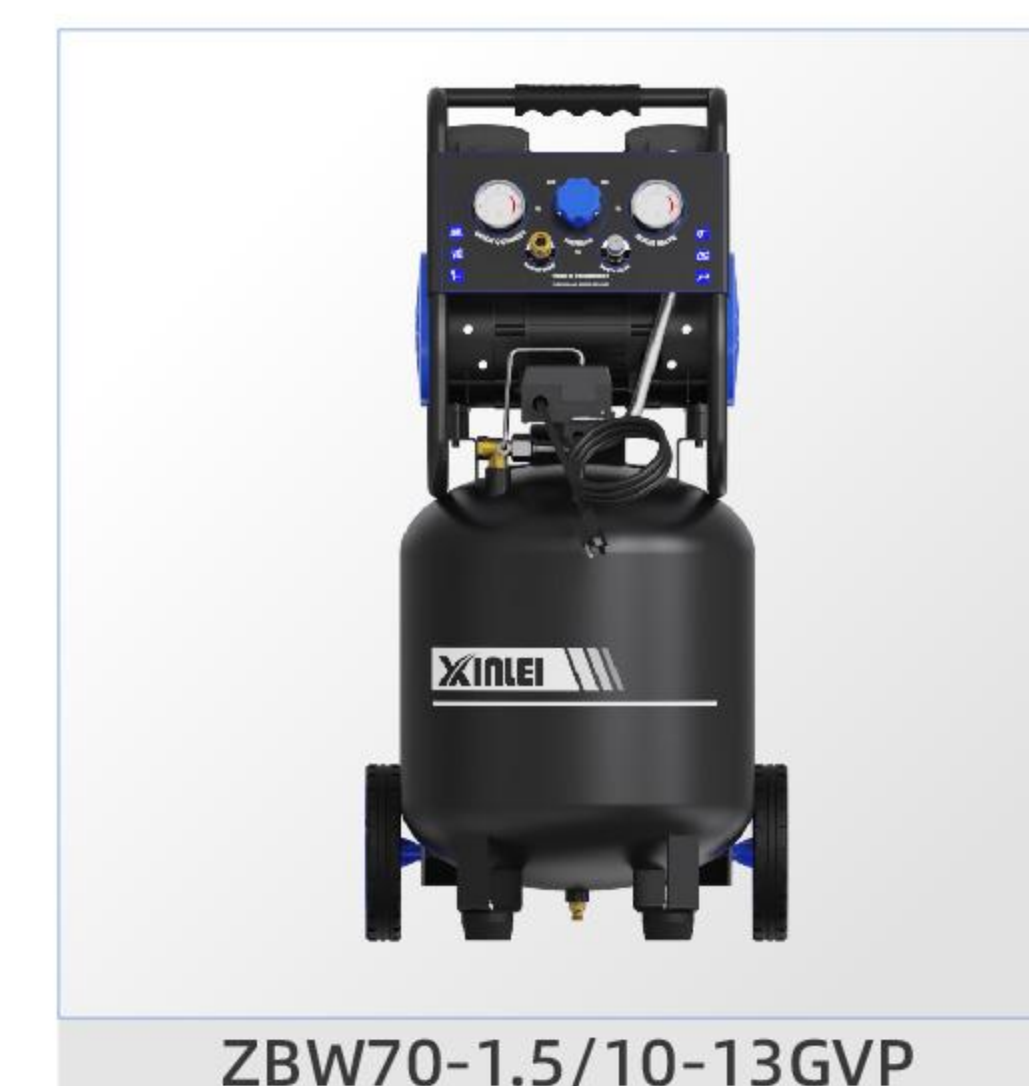

ZBW70-1.5/10-13GVP



ZBW70-4.5/10-150L



ZBW70-4.5/10-200L



ZBW70-6/10-200L

SLIENT OIL-FREE

- 100% oil-free & clean
- Compact and portable
- Motor with built-in PTC thermal protection
- Low noise, quiet operation
- Industrial-grade piston and piston ring
- Multi-head combination by displacement

Spray gun Nail gun Home decoration Tire inflation Equipment cleaning

LITHIUM BATTERY

- 100% oil-free & clean
- Compact and portable
- Light weight, easy to carry outdoors
- Low noise, quiet operation
- Driven by 20V/40V lithium battery brushless motor
- Silent brushless head structure

Spray gun Nail gun Home decoration Tire inflation Equipment cleaning



ZBWPM64-1.1/8



ZBWPM64-1.1/10-24L



ZBWPM64-1.1/10-50L
ZBWPM64-2.2/10-50L



ZBWPM64A-1.1/8-24L



ZBWPM64A-1.1/8-50L



ZBWPM64V-2.2/10-50L



ZBW58-0.55/8-BOX(20V)



ZBW58-0.95/8-6L(40V)

DIRECT DRIVEN PISTON AIR COMPRESSOR



DIRECT DRIVEN PISTON AIR COMPRESSOR

Choose Your Skin 



Customize your logo

DIRECT DRIVEN

- Integrated structure
- Oil-lubricated
- Simple operation and maintenance
- Wide pressure range
- Excellent piston sealing
- Motor with built-in PTC thermal protection

Spray gun Nail gun Home decoration Tire inflation Equipment cleaning

DIRECT DRIVEN

- Integrated structure
- Oil-lubricated
- Simple operation and maintenance
- Wide pressure range
- Excellent piston sealing
- Motor with built-in PTC thermal protection

Spray gun Nail gun Home decoration Tire inflation Equipment cleaning



BM-1.1/8-24L
 BM-1.5/8-24L
 BM-1.8/10-24L
 BM-1.1/8-24L-J



BM-1.5/8-16F
 BM-1.8/10-16F



BM-1.5/8-50L
 BM-1.8/10-50L
 BM-1.1/8-50L-J



BM-1.5/8-10GV
 BM-1.5/8-10GVP



BM-1.5/8-13GV
 BM-1.5/8-13GVP
 BM-1.8/10-13GV
 BM-1.8/10-13GVP



BM-1.5/8-20GVP
 BM-1.8/10-20GVP

DIRECT DRIVEN

- Integrated structure
- Oil-lubricated
- Simple operation and maintenance
- Wide pressure range
- Excellent piston sealing
- Motor with built-in PTC thermal protection

Spray gun

Nail gun

Home decoration

Tire inflation

Equipment cleaning



FL-1.1/8-24L FL-1.1/8-24L-J
FL-1.5/8-24L



FL-1.1/8-50L FL-1.8/10-50L
FL-1.5/8-50L FL-1.1/8-50L-J



FL-1.5/8-10GV



FL-1.5/8-13GV FL-1.5/8-13GVP
FL-1.8/10-13GV FL-1.8/10-13GVP

DIRECT DRIVEN

- Integrated structure
- Oil-lubricated
- Simple operation and maintenance
- Wide pressure range
- Excellent piston sealing
- Motor with built-in PTC thermal protection

Spray gun

Nail gun

Home decoration

Tire inflation

Equipment cleaning



VFL-2.2/10-24F



VZB-2.2/10-50L(F)
VFLA-2.2/10-50L
VZB-2.2/10-50L(B)



VFL-2.2/10-100L
VFLA-2.2/10-100L

DIRECT DRIVEN

- Integrated structure
- Oil-lubricated
- Simple operation and maintenance
- Wide pressure range
- Excellent piston sealing
- Motor with built-in PTC thermal protection

Spray gun Nail gun Home decoration Tire inflation Equipment cleaning

BELT DRIVEN

- Integrated structure
- Oil-lubricated
- Simple operation and maintenance
- Wide pressure range
- Excellent piston sealing
- Motor with built-in PTC thermal protection

Spray gun Nail gun Home decoration Tire inflation Equipment cleaning



XA4230-0.75/8-8L
XA4830-1.1/8-8L
XA4230-0.75/8-8L-J
XA4830-0.75/8-8L-J



XA4230-0.75/8-24L
XA4830-1.1/8-24L
XA4230-0.75/8-24L-J
XA4830-1.1/8-24L-J



XA4830-1.1/8-50L



1051-0.75/8-30L
1051-0.75/8-50L



ZA55-2/10-50L
ZA55-2/10-100L



ZA65-2.2/10-50L
ZA65-2.2/10-100L



ZA65-2.2/10-50L
ZA65-2.2/10-100L



2055Z-1.8/10-50L
2055Z-2.2/10-50L



2065Z-2.2/10-100L

BELT DRIVEN

BELT DRIVEN

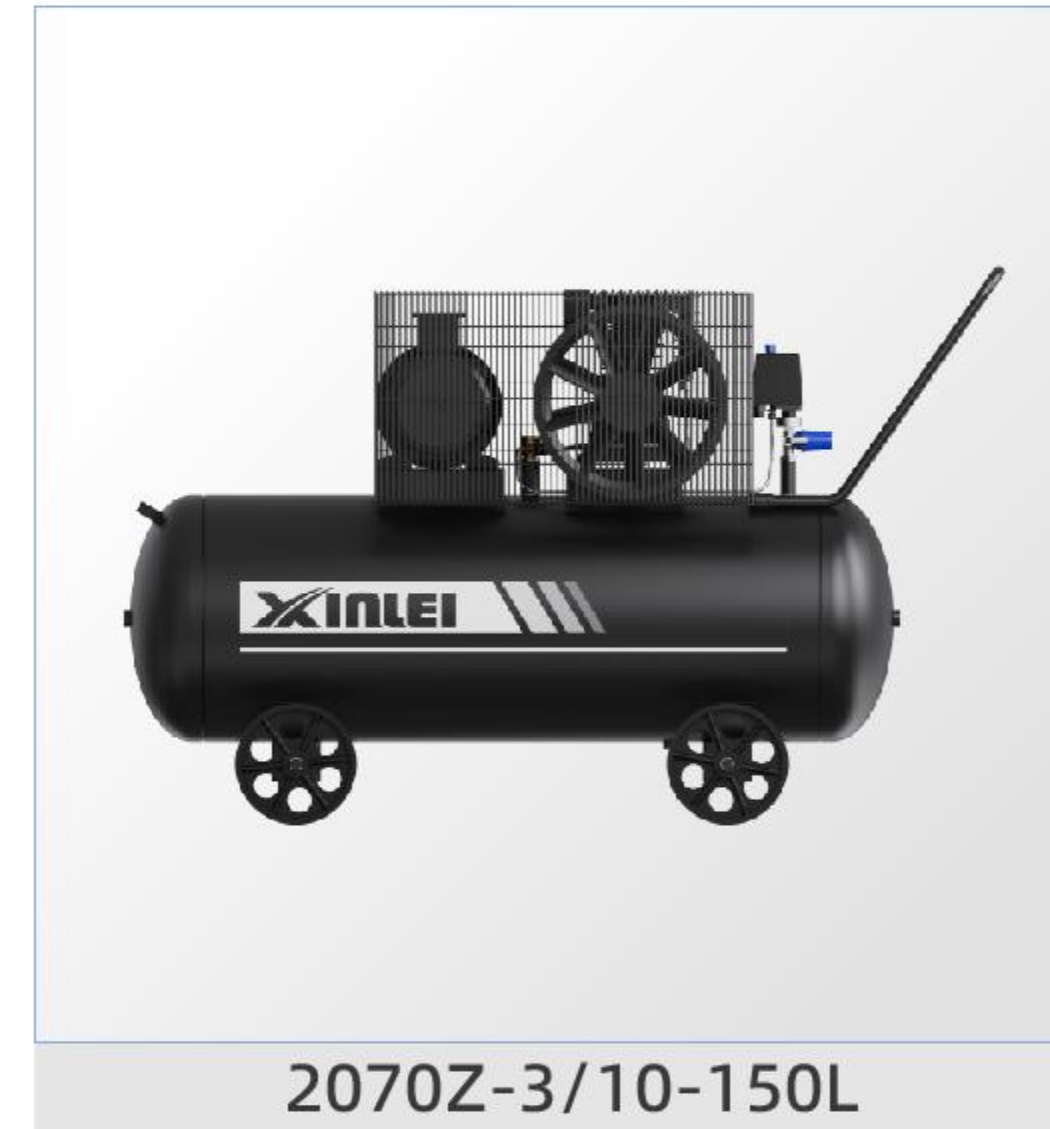

2070Z-3/10-150L



VD65-2.2/10-50L
VD65-2.2/10-60L
VD65-2.2/10-100L
VD65-2.2/10-120L
VD65-2.2/10-240L



VD80-4/10-300L
VD90-5.5/10-200L



TD80-5.5/10-500L



TD90-5.5/10-500L



TD65-3/10-105L



VD65-2.2/10-120LV



ZA2070A-2.2/10-100L



ZA2070A-3/10-120L



ZA2080A-4/10-150L

ACCESSORIES



PLUG
(European)



South African Britain American Australian Italian Switzerland



REGULATOR
(BM style)



BM style square BM style round round four pass square four pass round style Oil-water separator Filter style



AIR FILTER
(BM style G1/2)



BM style-iron G1/2 FL Style M16x1.5 ABAC style M16x1.5 Mute G-style R1/4 BM styl-small G1/2 Mute style-plastic R1/4 Mute style-iron R1/4



PRESSURE GAUGE



φ40+φ50 Radial iron φ40+φ50 Axial iron φ40+φ50 Axial chrome plating φ40+φ50 Axial plastic

ACCESSORIES



WHEEL
(Rubber 5/7/8 inch)



BP style rubber 5 inch Rubber 6 inch G-style rubber 7 inch Inflatable 8 inch Foam 8 inch Plastic 5 inch Rubber 7/8 inch



RELEASE VALVE
(Universal quick coupler R1/4)



American quick coupler R1/4 Britain quick coupler R1/4 Japanese quick coupler R1/4 European quick coupler R1/4 Push-pull valve G1/4-R1/4 Ball valve G1/4-R1/4



SAFETY VALVE
(CE plastic cap R1/4)



CE copper cap R1/4 General R1/4 ASME NPT1/4 R1/4 R1/4



PRESSURE SWITCH
(vertical single pass Rp1/4)



Vertical four pass 4-Rp1/4 Horizontal single pass Rp1/4 Hhorizontal four pass 4-Rp1/4 Rp1/4 4-Rp1/4



BREATH PIPE
(General style φ18)



AH style φ18 V style φ18 M16*1.5 G1/8